

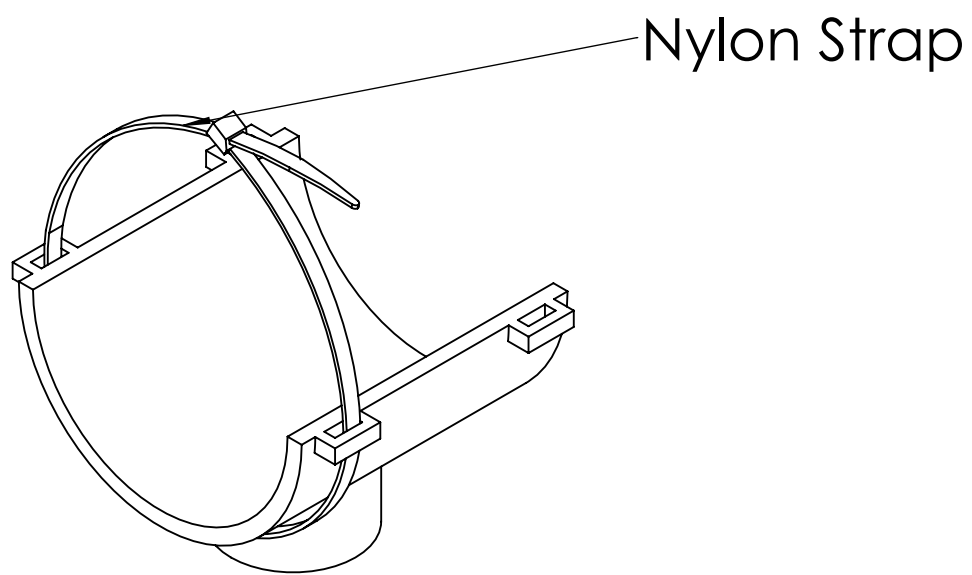

APS-2  
Saddle

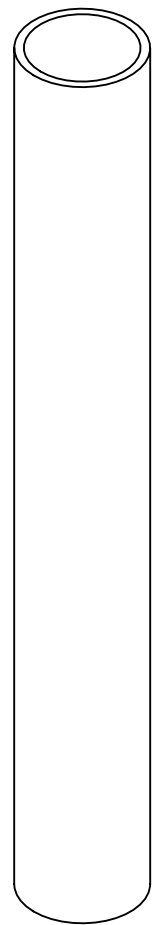

3/4" Schedule 40  
PVC Electrical Conduit  
(Cut to Length Required)



Assembled APS-2

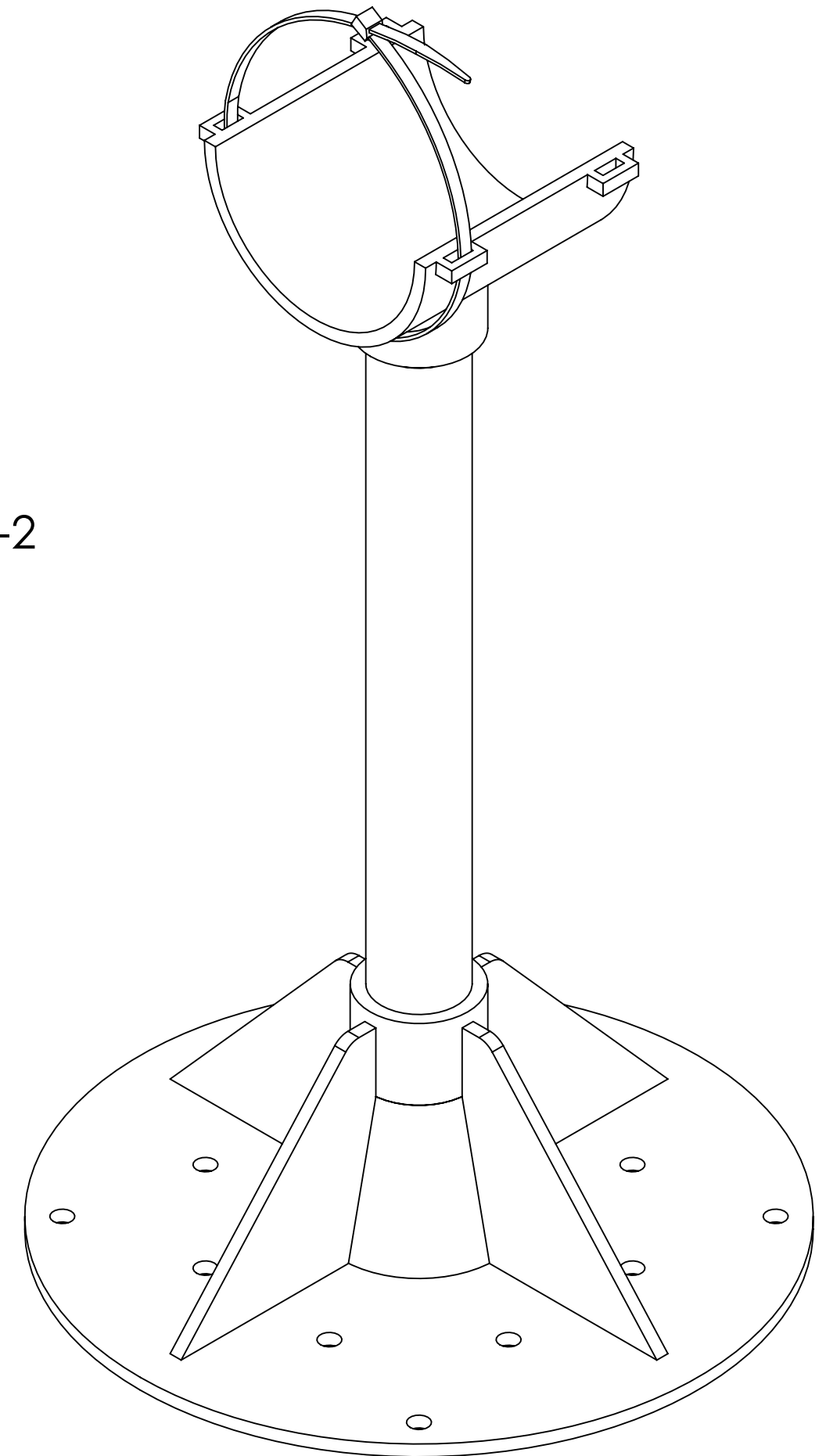

Pipe Prop  
Circular Base

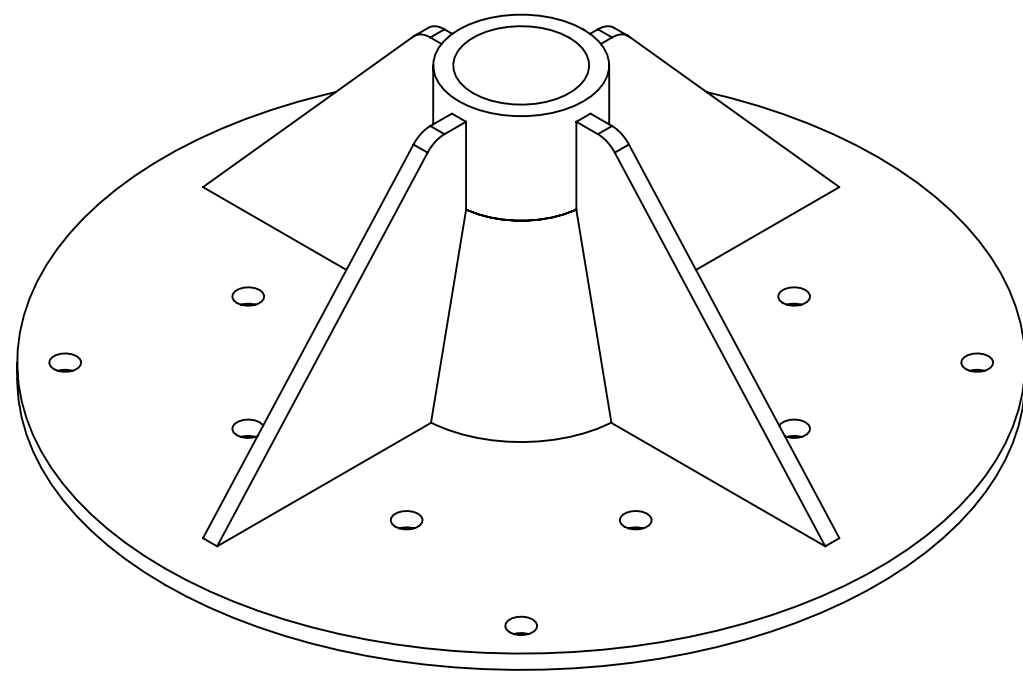

**PROPRIETARY AND CONFIDENTIAL**  
THE INFORMATION CONTAINED IN THIS DRAWING IS THE SOLE PROPERTY OF PIPE PROP. ANY REPRODUCTION IN PART OR AS A WHOLE WITHOUT THE WRITTEN PERMISSION OF PIPE PROP IS PROHIBITED.

		UNLESS OTHERWISE SPECIFIED:		NAME	DATE		
		DIMENSIONS ARE IN INCHES		DRAWN		TITLE: APS-2	
		TOLERANCES:		CHECKED			
		FRACTIONAL ±		ENG APPR.			
		ANGULAR: MACH ± BEND ±		MFG APPR.			
		TWO PLACE DECIMAL ±		Q.A.			
		THREE PLACE DECIMAL ±		COMMENTS:			
		INTERPRET GEOMETRIC TOLERANCING PER:				SIZE	DWG. NO.
		MATERIAL				<b>C</b>	REV
NEXT ASSY	USED ON	FINISH				SCALE: 1:2 WEIGHT: SHEET 4 OF 7	
APPLICATION		DO NOT SCALE DRAWING					